

MODEL PAXCDS -SETPOINT OUTPUT PLUG-IN OPTION CARDS

DESCRIPTION

This bulletin serves as a guide for the installation, configuration and operation of PAX Setpoint cards. The setpoint cards are available as dual relay, quad relay, quad sourcing transistor, or quad sinking transistor outputs. Only one setpoint card can be installed at a time.

The PAX meter can be fitted with up to three option cards. The slot bays of the option cards are dedicated to a particular card function. The option card functions are: serial communications, analog output and setpoint output. Only one card from each function category can be installed.

INSTALLING AN OPTION CARD



Caution: The option and main circuit cards contain static sensitive components. Before handling the cards, discharge static charges from your body by touching a grounded bare metal object. Ideally, handle the cards at a static controlled clean workstation. Also, only handle the cards by the edges. Dirt, oil or other contaminants that may contact the cards can adversely affect circuit operation.



Warning: Exposed line voltage exists on the circuit boards. Remove all power to the meter AND load circuits before accessing the unit.

1. Remove the main assembly from the rear of the case. Squeeze the finger holds on the rear cover, or use a small screwdriver to depress the side latches to release it from the case. It is not necessary to separate the rear cover from the main circuit card.
2. Locate the option card connector for the type of option card to be installed. Hold the unit by the rear connector, not the display board, when installing an option card.
3. Install the option card by aligning the option card connector with the slot in the rear cover. The cards are keyed by position with different main board connector locations. Be sure the connector is fully engaged and the tab on the option card rests in the alignment slot on the display board.
4. Slide the assembly back into the case. Be sure the rear cover latches fully into the case.
5. Apply the option card label to the bottom side of the meter. **Do not cover the vents on the top surface of the meter.** The surface of the case must be clean for the label to adhere properly. Apply the label to the area designated by the large case label.

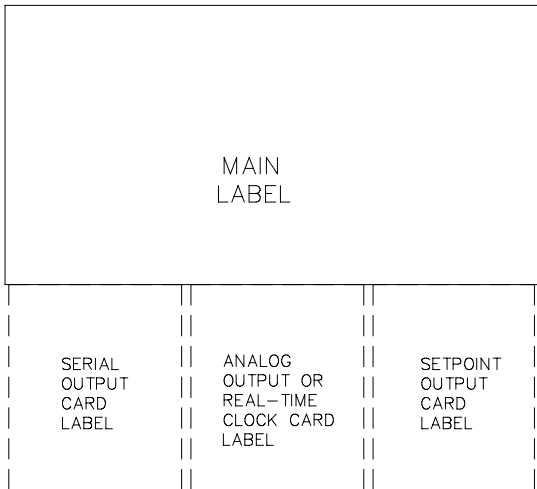
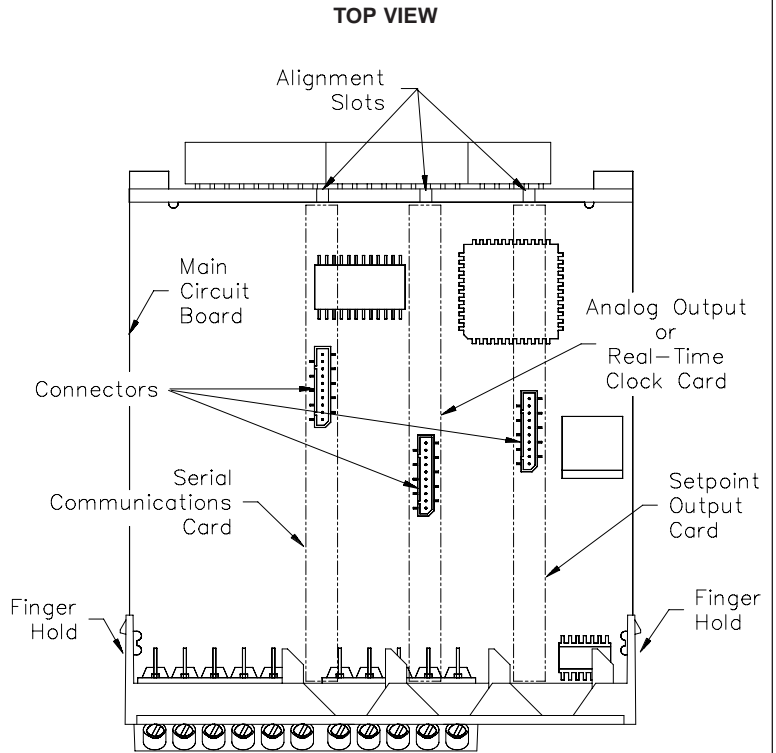

PAX REAR TERMINAL CONNECTIONS

DUAL RELAY PAXCDS10 OUTPUT FIELD TERMINALS

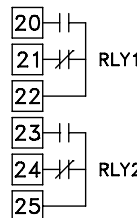

QUAD RELAY PAXCDS20 OUTPUT FIELD TERMINALS

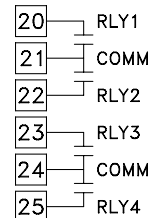

QUAD SINKING PAXCDS30 OUTPUT FIELD TERMINALS

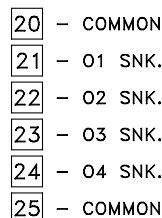

QUAD SOURCING PAXCDS40 OUTPUT FIELD TERMINALS

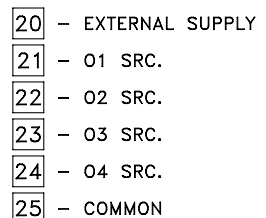

SPECIFICATIONS

Setpoint Output Cards: Four types of field installable cards

Response Time: 200 msec. max. to within 99% of final readout value (digital filter and internal zero correction disabled) 700 msec. max. (digital filter disabled, internal zero correction enabled)
 PAXH only: 1 sec. max. to within 99% of final readout value (digital filter disabled)

PAXT only: 200 msec. typ.; 700 msec max. (digital filter disabled)

PAXH Isolation For All Four Cards:

Isolation To Sensor Common: 1400 Vrms for 1 min.

Working Voltage: 125 V

Isolation To User Input Common: 500 Vrms for 1 min.

Working Voltage: 50 V

Dual Relay Card: PAXCDS10

Type: Two FORM-C relays

Isolation To Sensor & User Input Commons: 2000 Vrms for 1 min.

Working Voltage: 250 V

Contact Rating:

One Relay Energized: 5 amps @ 120/240 VAC or 28 VDC (resistive load), 1/8 HP @ 120 VAC, inductive load

Total Current With Both Relays Energized not to exceed 5 amps

Life expectancy: 100 K cycles min. at full load rating. External RC snubber extends relay life for operation with inductive loads

Quad Relay Card: PAXCDS20

Type: Four FORM-A relays

Isolation To Sensor & User Input Commons: 2300 Vrms for 1 min.

Working Voltage: 250 V

Contact Rating:

One Relay Energized: 3 amps @ 250 VAC or 30 VDC (resistive load), 1/10 HP @ 120 VAC, inductive load

Total Current With All Four Relays Energized not to exceed 4 amps

Life Expectancy: 100 K cycles min. at full load rating. External RC snubber extends relay life for operation with inductive loads

Quad Sinking Open Collector: PAXCD30

Type: Four isolated sinking NPN transistors.

Isolation To Sensor & User Input Commons: 500 Vrms for 1 min.

Working Voltage: 50 V. Not Isolated from all other commons.

Rating: 100 mA max @ $V_{SAT} = 0.7$ V max. $V_{MAX} = 30$ V

Quad Sourcing Open Collector: PAXCD40

Type: Four isolated sourcing PNP transistors.

Isolation To Sensor & User Input Commons: 500 Vrms for 1 min.

Working Voltage: 50 V. Not Isolated from all other commons.

Rating: Internal supply: 24 VDC $\pm 10\%$, 30 mA max. total all four
 External supply: 30 VDC max., 100 mA max each output

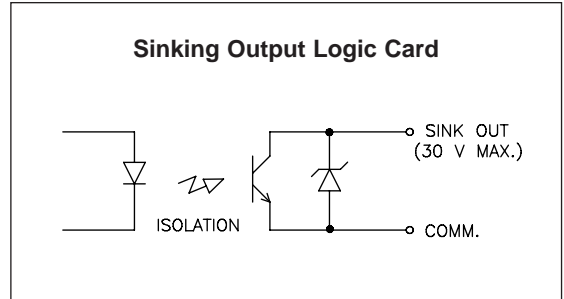
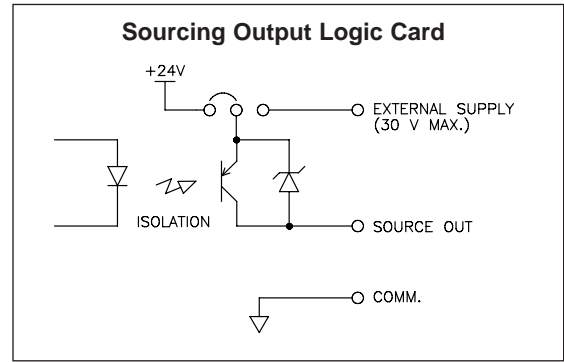

Quad Sourcing Open Collector Output Card Supply Select

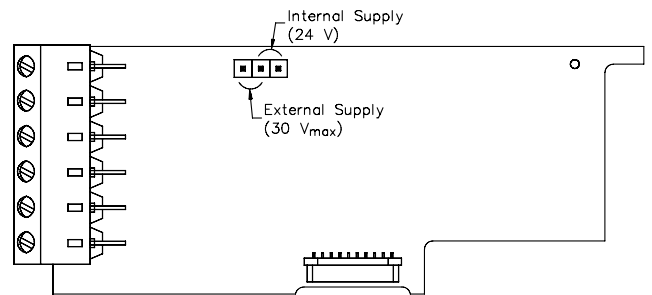

For Quad Sourcing Plug-in Card (PAXCDS40), set the jumper for internal or external supply operation before applying power.

ORDERING INFORMATION

MODEL	DESCRIPTION	PART NUMBER
PAXCDS	Dual Relay Output Card	PAXCDS10
	Quad Relay Output Card	PAXCDS20
	Quad Sinking Open Collector Output Card	PAXCDS30
	Quad Sourcing Open Collector Output Card	PAXCDS40

MODULE 6 - Setpoint (Alarm) Parameters (6-5Pt)

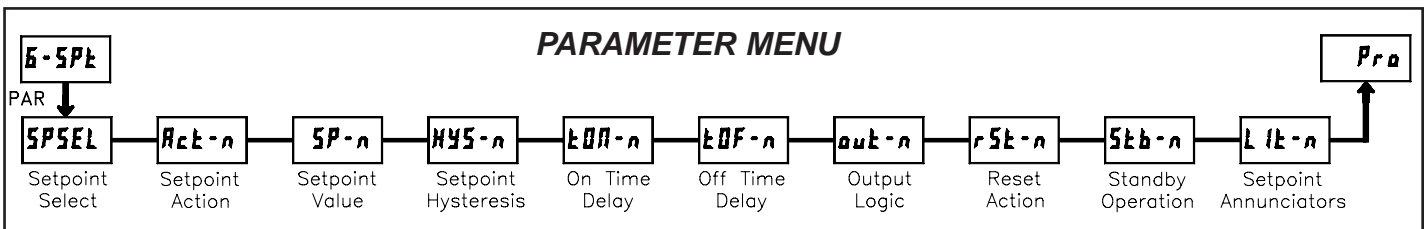

SETPOINT SELECT

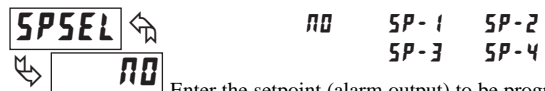
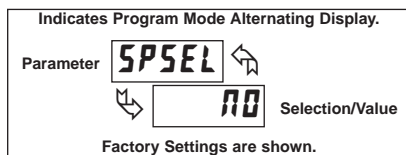

Enter the setpoint (alarm output) to be programmed. The *n* in the following parameters will reflect the chosen setpoint number. After the chosen setpoint is completely programmed, the display will return to *SPSEL n0*. Repeat step for each setpoint to be programmed. The *n0* chosen at *SPSEL* will return to *Pra n0*. The number of setpoints available is setpoint output card dependent.

SETPOINT ACTION

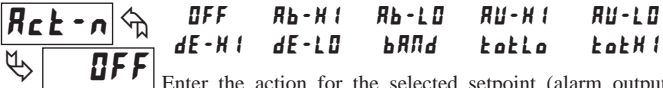

Enter the action for the selected setpoint (alarm output).
See Setpoint Alarm Figures for a visual detail of each action.

- OFF** = Setpoint always off, (returns to SPSEL NO)
- Ab-HI** = Absolute high, with balanced hysteresis
- Ab-LO** = Absolute low, with balanced hysteresis
- AU-HI** = Absolute high, with unbalanced hysteresis
- AU-LO** = Absolute low, with unbalanced hysteresis
- dE-HI** = Deviation high, with unbalanced hysteresis *
- dE-LO** = Deviation low, with unbalanced hysteresis *
- bAND** = Outside band, with unbalanced hysteresis *
- kLkLo** = Lower Totalizer absolute high, unbalance hysteresis**
- kLkHI** = Upper Totalizer absolute high, unbalance hysteresis**

* Deviation and band action setpoints are relative to the value of setpoint 1. It is not possible to configure setpoint 1 as deviation or band actions. It is possible to use setpoint 1 for an absolute action, while its value is being used for deviation or band.

** The lower Totalizer action **kLkLo** allows setpoints to function off of the lower 5 digits of the Totalizer. The upper Totalizer action **kLkHI** allows setpoints to function off of the upper 4 digits of the Totalizer. To obtain absolute low alarms for the Totalizer, program the **kLkLo** or **kLkHI** output logic as reverse.

SETPOINT VALUE

- 99999 to 99999



Enter desired setpoint alarm value. These setpoint values can also be entered in the Display Mode during Program Lock-out when the setpoint is programmed as **Enk** in Parameter Module 3. When a setpoint is programmed as deviation or band acting, the associated output tracks **SP 1** as it is changed. The value entered is the offset, or difference from **SP 1**.

HYSTERESIS VALUE

1 to 65000



Enter desired hysteresis value. See Setpoint Alarm Figures for visual explanation of how setpoint alarm actions (balance and unbalance) are affected by the hysteresis. When the setpoint is a control output, usually balance hysteresis is used. For alarm applications, usually unbalanced hysteresis is used. For unbalanced hysteresis modes, the hysteresis functions on the low side for high acting setpoints and functions on the high side for low acting setpoints.

Note: Hysteresis eliminates output chatter at the switch point, while time delay can be used to prevent false triggering during process transient events.

Setpoint Alarm Figures

With reverse output logic **rEu**, the below alarm states are opposite.

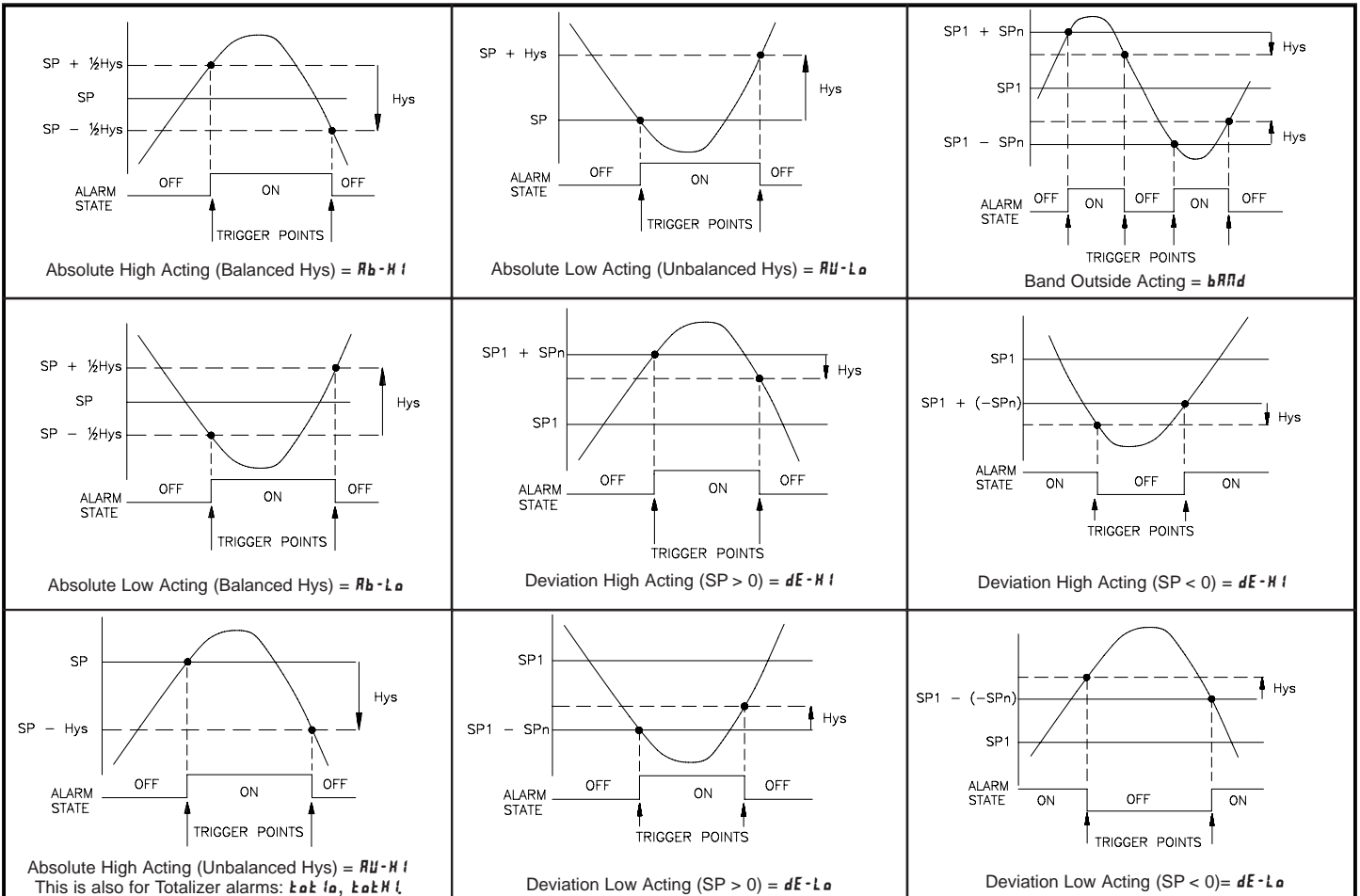

ON TIME DELAY



00 to 32750 Sec

Enter the time value in seconds that the alarm is delayed from turning on after the trigger point is reached. A value of 0.0 allows the meter to update the alarm status per the response time listed in the Specifications. When the output logic is **rEu**, this becomes off time delay. Any time accumulated at power-off resets during power-up.

OFF TIME DELAY

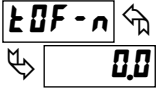

00 to 32750 Sec

Enter the time value in seconds that the alarm is delayed from turning off after the trigger point is reached. A value of 0.0 allows the meter to update the alarm status per the response time listed in the Specifications. When the output logic is **rEu**, this becomes on time delay. Any time accumulated at power-off resets during power-up.

OUTPUT LOGIC

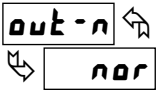

nor rEu

Enter the output logic of the alarm output. The **nor** logic leaves the output operation as normal. The **rEu** logic reverses the output logic. In **rEu**, the alarm states in the Setpoint Alarm Figures are reversed.

RESET ACTION

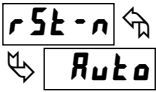

Auto LATCH 1 LATCH 2

Enter the reset action of the alarm output.

Auto = Automatic action; This action allows the alarm output to automatically reset off at the trigger points per the Setpoint Action shown in Setpoint Alarm Figures. The "on" alarm may be manually reset (off) immediately by a front panel function key or user input. The alarm remains reset off until the trigger point is crossed again.

LATCH 1 = Latch with immediate reset action; This action latches the alarm output on at the trigger point per the Setpoint Action shown in Setpoint Alarm Figures. Latch means that the alarm output can only be turned off by front panel function key or user input manual reset, serial reset command or meter power cycle. When the user input or function key is activated (momentary or maintained), the corresponding "on" alarm output is reset immediately and remains off until the trigger point is crossed again. (Previously latched alarms will be off if power up Display Value is lower than setpoint value.)

LATCH 2 = Latch with delay reset action; This action latches the alarm output on at the trigger point per the Setpoint Action shown in Setpoint Alarm Figures. Latch means that the alarm output can only be turned off by front panel function key or user input manual reset, serial reset command or meter power cycle. When the user input or function key is activated (momentary or maintained), the meter delays the event until the corresponding "on" alarm output crosses the trigger off point. (Previously latched alarms are off if power up Display Value is lower than setpoint value. During a power cycle, the meter erases a previous Latch 2 reset if it is not activated at power up.)

STANDBY OPERATION



no YES

When **YES**, the alarm is disabled (after a power up) until the trigger point is crossed. Once the alarm is on, the alarm operates normally per the Setpoint Action and Reset Mode.

SETPOINT ANNUNCIATORS

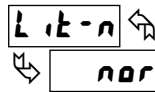

OFF nor rEu FLASH

The **OFF** mode disables display setpoint annunciators. The **nor** mode displays the corresponding setpoint annunciators of "on" alarm outputs. The **rEu** mode displays the corresponding setpoint annunciators of "off" alarms outputs. The **FLASH** mode flashes the corresponding setpoint annunciators of "on" alarm outputs.

PROBE BURN-OUT ACTION (PAXT ONLY)



ON OFF

Enter the probe burn-out action. In the event of a temperature probe failure, the alarm output can be programmed to go on or off.

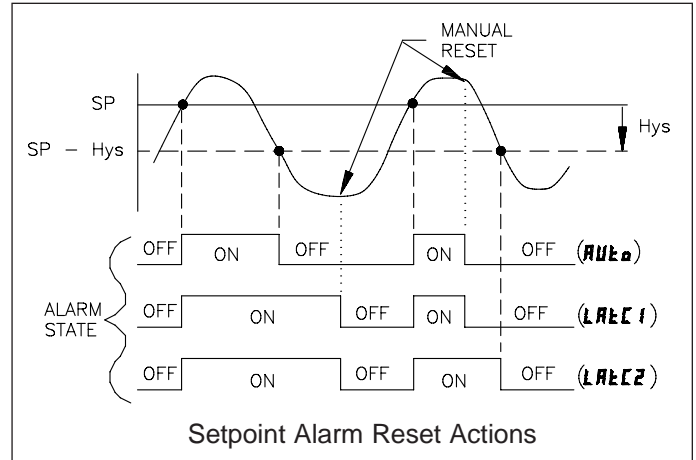

Alternate Setpoints

An Alternate list of setpoint values can be stored and recalled as needed. The Alternate list allows an additional set of setpoint values. (The setpoint numbers nor rear terminal numbers will change in the Alternate list.) The Alternate list can only be activated through a function key or user input programmed for **L15E** in Module 2. When the Alternate list is selected, the Main list is stored and becomes inactive. When changing between Main and Alternate, the alarm state of Auto Reset Action alarms will always follow their new value. Latched "on" alarms will always stay latched during the transition and can only be reset with a user input or function key. Only during the function key or user input transition does the display indicate which list is being used.

LIMITED WARRANTY

The Company warrants the products it manufactures against defects in materials and workmanship for a period limited to one year from the date of shipment, provided the products have been stored, handled, installed, and used under proper conditions. The Company's liability under this limited warranty shall extend only to the repair or replacement of a defective product, at The Company's option. The Company disclaims all liability for any affirmation, promise or representation with respect to the products.

The customer agrees to hold Red Lion Controls harmless from, defend, and indemnify RLC against damages, claims, and expenses arising out of subsequent sales of RLC products or products containing components manufactured by RLC and based upon personal injuries, deaths, property damage, lost profits, and other matters which Buyer, its employees, or sub-contractors are or may be to any extent liable, including without limitation penalties imposed by the Consumer Product Safety Act (P.L. 92-573) and liability imposed upon any person pursuant to the Magnuson-Moss Warranty Act (P.L. 93-637), as now in effect or as amended hereafter.

No warranties expressed or implied are created with respect to The Company's products except those expressly contained herein. The Customer acknowledges the disclaimers and limitations contained hererin and relies on no other warranties or affirmations.